

Loseplat by ITM plastic modular tiles, made of polypropylene, are characterized by their great versatility and the possibility of using them in indoor and outdoor areas.

Main characteristics:

- They can be used indoors and outdoors.
- They are made of polypropylene.
- They have a non-slip surface.
Prevent slips and falls.
- They turn wet surfaces into dry walkways to ensure people's safety.
- They avoid areas with puddles. Its design favors the water drainage and the stability of the piece.
- Assembly is very simple. They use a tongue and groove assembly system to facilitate their placement.
- In addition, plastic tiles can easily be cut with a saw to be adapted to the contours and elements present in the installation area.
- They renew the appearance of aged or worn floors.
- They resist the corrosion of chemical products. They are not deformed by cold or heat.
- They withstand sun and ultraviolet exposure.
- They have a thickness of 17 mm.
- They are easy to clean and maintain.

Our plastic tiles are suitable for all types of floors but they are especially useful for areas with high humidity.

Outdoor tile for use in:

- Gardens, terraces and balconies
- Swimming pools and jacuzzis
- Tents for events and exhibitions
- Nautical boats
- Camping

Outdoor tile for use in:

- Kitchens, bars, wine cellars and restaurants
- Cold rooms rooms
- Bathrooms and saunas
- Garages Workshops and workspaces in general

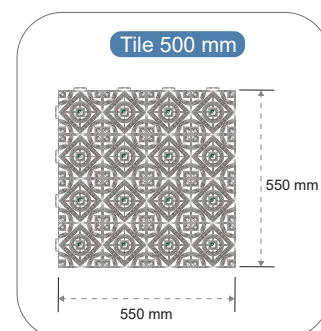
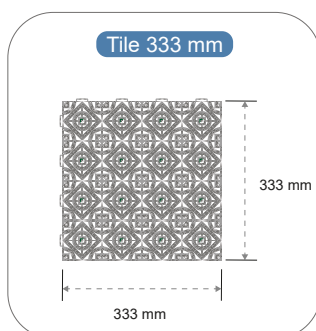
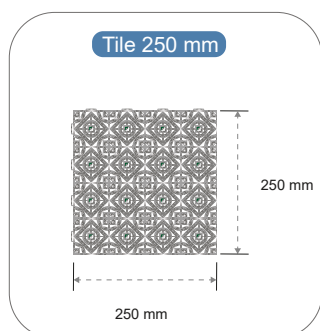

Technical features		Model 250x250
Code		009 117 001
Material		Polypropylene
Dimensions		Width: 250 mm Length: 250 mm Height: 17 mm
Colour		Green, grey and terracotta
Unit weight		0,228 Kg
No. of pieces per square meter		16
Weight per square meter		3,66 Kg
Packing		Pallet 115x115 16 columns x 100 heights 1600 pieces

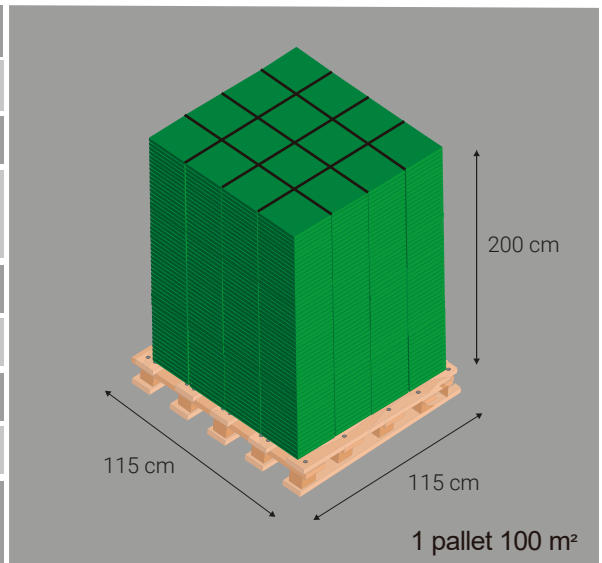

Technical features		Model 333x333
Code		009 111 001
Material		Polypropylene
Dimensions		Width: 333 mm Length: 333 mm Height: 17 mm
Colour		Green, grey and terracotta
Unit weight		0,410 Kg
No. of pieces per square meter		9
Weight per square meter		3,69 Kg
Packing		Pallet 115x115 9 columns x 100 heights 900 pieces

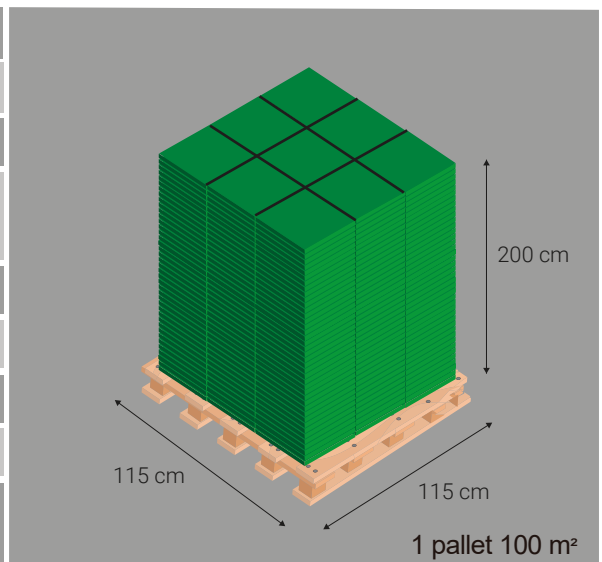

Technical features		Model 500x500
Code		009 115 001
Material		Polypropylene
Dimensions		Width: 500 mm Length: 500 mm Height: 17 mm
Colour		Green, grey and terracotta
Unit weight		0,915 Kg
No. of pieces per square meter		4
Weight per square meter		3,66 Kg
Packing		Pallet 115x115 4 columns x 100 heights 400 pieces

